



Estimating biochar yield per hectare from logging residues in *Eucalyptus globulus* stands

S. Pérez^{a,*}, J. Fernandez-Ferreras^b, I. Fernandez^a, L. Pérez^b

^a Department of Energy Engineering, Universidad de Cantabria, Spain

^b Department of Chemistry and Process and Resources Engineering, Universidad de Cantabria, Spain

ARTICLE INFO

Keywords:

Logging residues
Eucalyptus globulus
 Slow pyrolysis
 Biochar
 Response Surface Methodology

ABSTRACT

Eucalyptus globulus is widely cultivated for wood production due to its high fiber quality and pulp yield. However, large amounts of residual biomass are generated during harvesting, posing disposal challenges. Converting these residues into value-added products is required. One promising approach is the biochar production using pyrolysis. This study assessed the potential biochar yield from logging residues in *Eucalyptus globulus* stands. The residual biomass harvested was quantified based on the number of logging residue compacted bales (CRLs). A set of equations were fitted to calculate the residual biomass harvested in stands depending on their quality. Pyrolysis tests of residue components (leaves, bark, and branches) were conducted using a response surface methodology (RSM). Additionally, per-hectare revenues from biochar sales via pyrolysis were compared to those from electricity sales via residue combustion. The results showed that the number of CRLs and the volume of debarked wood (m³) ratio was around 0.5, being the collection process efficiency 0.69 ± 0.09 . There was a positive correlation between the harvested residual biomass and quality stand, with a difference of 61 t ha^{-1} between the highest and lowest quality stands. The highest biochar yields in order were leaves > bark > branches. The peak value was 61.27% at 300 °C and 0.1 L min⁻¹ N₂ flow. The RSM analysis indicated temperature, the square of N₂ flow and the square of temperature as significant factors ($p < 0.05$). The biochar yield of the total residue ranged from 49.1% at 300 °C to 27.94% at 600 °C. Under optimal pyrolysis conditions, the estimated biochar yield per hectare ranged from 46.8 to 17.3 t ha⁻¹, depending on quality stands. Revenue per hectare from the sale of biochar accounted for 60% of the revenue from the sale of electricity.

1. Introduction

The rising demand for renewable energy and effective carbon management has further heightened interest in biomass as a resource. Lignocellulosic biomass has emerged in recent decades as a viable feedstock for the future bioeconomy (Londo et al., 2018).

Forests play a dual role, serving both as a source of energy and as vital carbon sinks. Carbon accumulation in trees is closely tied to their growth rate, making fast-growing forest species particularly effective in enhancing carbon fixation rates. Among forest species, the *Eucalyptus* genus stands out for its exceptional capacity to generate biomass (Sims et al., 1999). Within this genus, *Eucalyptus globulus* (Labill) is one of the most representative and widely used species worldwide for wood production in the paper industry, due to the quality of its fibers and the high pulp yield of its wood, making it one of the preferred species for the production of high-quality cellulose (Kibblwhite et al., 2000).

However, factors such as temperatures below 0 °C, restrict its cultivation to regions with mild climates. Despite this, *Eucalyptus globulus* (Labill) produces pulpwood worldwide in countries such as Spain, Portugal, Brazil, Chile, Argentina, Uruguay, the United States, Australia, Nigeria, and New Zealand (ENCE, 2021). The residues from the logging of this species (leaves, branches (diameter <7 cm), and bark) generate biomass that can be converted into energy and/or high-value-added products, contributing to reach the United Nations' Sustainable Development Goals, specifically goals 7 (affordable and clean energy), 8 (decent work and economic growth), 12 (responsible consumption and production), 13 (climate action) and 15 (life on land), which should guide our efforts. Residues from the logging of *Eucalyptus globulus* are by-products of wood harvesting operations, as only the debarked wood is valuable for pulp production (Pereira et al., 2003). Generally, the residues are left in piles along the forest tracks by the forestry processor after the harvest, although in some cases, they may be scattered across the entire plot

* Corresponding author.

E-mail address: perezrs@unican.es (S. Pérez).

<https://doi.org/10.1016/j.indcrop.2025.121098>

Received 12 March 2025; Received in revised form 16 April 2025; Accepted 24 April 2025

Available online 6 May 2025

0926-6690/© 2025 The Authors. Published by Elsevier B.V. This is an open access article under the CC BY-NC-ND license (<http://creativecommons.org/licenses/by-nc-nd/4.0/>).

depending on its slope. The technologies employed to collect these residues and enhance their density involve chipping them into chips or compacting them into cylindrical bales (logging residues compacted (CRL's) with a diameter of 0.7 m and a length of 3 m) (Manzone, 2015; Velázquez Martí, 2006).

In recent years, substantial efforts have been devoted to quantifying the amount of generated residues per hectare, given their critical implications. These implications include their role as carbon sinks due to the carbon stored in them (García-Villabrille et al., 2014), the impact of residue extraction on soil fertility (Brañas et al., 2000), the energy density and potential energy yield per hectare (Mateos and Ormaetxea, 2019), as well as the determination of power requirements and optimal siting for combustion plants (Kumar et al., 2003). Initially, attempts to quantify the amount of residues in *Eucalyptus globulus* stands employed empirical mathematical models that establish relationships between biomass quantity generated, stem diameter outside bark at breast height (DBH), and total tree height (H), tailored to the specific conditions under which the trees were sampled (Gonzalez-Benecke et al., 2021; Kulmann et al., 2022; Oliveira and Tomé, 2017). Consequently, these models based on DBH and H obtained from experimental stands are influenced by variables such as age, planting density, site index, silvicultural treatments, planting quality, etc., all of which are intrinsic to the evaluated stands, leading to errors when applied and making their use challenging in industrial-scale plantations. To reduce this error and obtain equations which provide a more practical and accurate estimation of residual biomass generated in a real stand, the quantity of residues was estimated based on the stand's quality, determined by its productivity which is measured by the underbark wood volume at a specific age ($\text{m}^3 \text{ha}^{-1} \text{yr}^{-1}$) (Pérez et al., 2020a). Literature review has shown that the quantification of the forest biomass residues has been usually performed considering data of the forest growth rates obtained using models which estimate forest productivities (Vasco and Costa, 2009). A notable contribution of this study is the quantification of actual residual biomass harvested per hectare, through the logging residue bales (CRLs) produced by a Finnish Timberjack baler. It should be highlighted that the harvested biomass is inherently lower than the total generated biomass.

The commercial thermochemical process which valorizes these residues is combustion, achieving 15–30% efficiency in generating electricity and heat (Bridgwater, 2003; Nuñez-Regueira et al., 2002). Combustion drawbacks include difficulties in the storage of the produced energy produced and management ashes and emissions. On the other hand, pyrolysis has gained prominence as a thermochemical process for to produce high-value-added products. It is considered one of the most cost-effective and efficient methods for converting primary biomass into valuable resources (Bridgwater, 2003). This process is considered emission-neutral and has gained significant attention due to its ability to achieve high energy valorization relative to the initial energy content of biomass, as well as reducing biomass volume, thereby positively influencing environmental costs (Vecino Mantilla et al., 2014). Slow pyrolysis primarily produces biochar, bio-oil and syngas as by-products. Biochar is a material with a high carbon content produced when biomass is pyrolyzed, gasified, or carbonized in an environment with limited oxygen. According to Zanli et al. (2022) forest residues represent an underutilized source of energy and biochar. The carbon contained in biochar (fixed carbon) is highly stable, which means it can be used as a solution for carbon sequestration for hundreds or even thousands of years (Shalini and Raghavan, 2021). Biochar can also be utilized in various applications, including serving as a support material for direct catalysis (Mani et al., 2013), wastewater treatment for the removal of organic and inorganic pollutants in soil and aqueous systems (Cheng et al., 2025; Emenike et al., 2022; Houben et al., 2013), enhancing composting by improving microbial population structure and carbon mineralization (Zhang and Sun, 2014) and energy storage as an electrode material (Qian and Kumar, 2015; Zhang et al., 2023). Thus, producing biochar from residual biomass is particularly appealing, as it

not only helps solve waste disposal challenges but also generates value-added products in an environmentally sustainable way (Aydinli and Caglar, 2012). Numerous studies have investigated the pyrolysis of wood from various forest species (Grojzdek et al., 2021; Hu et al., 2019; Jarvis et al., 2014; Müller-Hagedorn et al., 2003) including *Eucalyptus globulus* (Wrobel-Tobiszewska et al., 2015) and even wood-plastic mixtures (Samal et al., 2021). Nonetheless, there is a lack of studies addressing the biochar production potential from residues, as well as the specific biochar yield per hectare from the individual residue components (leaves, bark, branches) of *Eucalyptus globulus*, despite its global significance as a biomass resource and the fact that there are authors (Qiu et al., 2023a) who have found significant variations in the biochar production from the tree different components of residue in the *Populus* genus.

To assess the biochar potential per hectare from *Eucalyptus globulus* residues, it is essential to first quantify the actual harvested biomass as accurately as possible. The objective of this study was accurately to evaluate the biochar production potential from *Eucalyptus globulus* plantations residues in northern Spain through slow pyrolysis, considering the actual amount of residual biomass harvested, quantified as the number of bales of compact logging residues (CRL's) per hectare. To achieve this, the study was divided into three specific objectives: (1) To estimate the residual biomass harvested per hectare, (2) To determine the quantitative influence of the pyrolysis conditions (factors) on the biochar yield (response) with the aim of obtaining valuable information for the subsequent economic optimization of the overall process, (3) To estimate the quantity of biochar as a function of stand quality.

The aim of this study is evaluate accurately the potential production of biochar through slow pyrolysis using residues from *Eucalyptus globulus* obtained in stands in northern Spain. To achieve that objective, it is essential to quantify the actual amount of harvested biomass as accurately as possible. This quantification has been done using the number of bales of compact logging residues (CRL's) per hectare. Once the calculation of the residual biomass harvested per hectare was carried out, the following targets of this paper have been: To determine the quantitative influence of the pyrolysis conditions (factors) on the biochar yield (response) to obtain valuable information for the subsequent economic optimization of the overall process and to estimate the quantity of biochar as a function of stand quality.

2. Materials and methods

2.1. Study area

The study was carried out in Cantabria, northern Spain (latitude 43°28' N, longitude 3°48' W), where *Eucalyptus globulus* plantations cover approximately 45,000 ha (Dirección General de Montes y Conservación de la Naturaleza del Gobierno de Cantabria, 2000). These stands are distributed across varied topography, with predominant soil types classified as Acrisols, Cambisols, and Umbrisols (Dirección General de Montes y Conservación de la Naturaleza del Gobierno de Cantabria, 2000). The region experiences an average annual rainfall of 1200–1500 mm, relatively well distributed throughout the year, although slightly lower in summer. Mean temperatures range from a maximum of 25 °C in the warmest month to a minimum of 6 °C in the coldest.

2.2. Harvested residual biomass quantification

Seventeen *Eucalyptus globulus* stands were selected in Cantabria, ranging in age from 12 to 26 years (Fig. 1a), ensuring representative sampling across the región. For each plot, information was available on surface area (ranged between 0.314 and 9 ha), age, and the volume of debarked stem wood recorded by a forestry processor. Residual biomass was quantified by counting the number of cylindrical bales (CRLs) of forest residues harvested, each approximately 3 m length and 0.7 m in

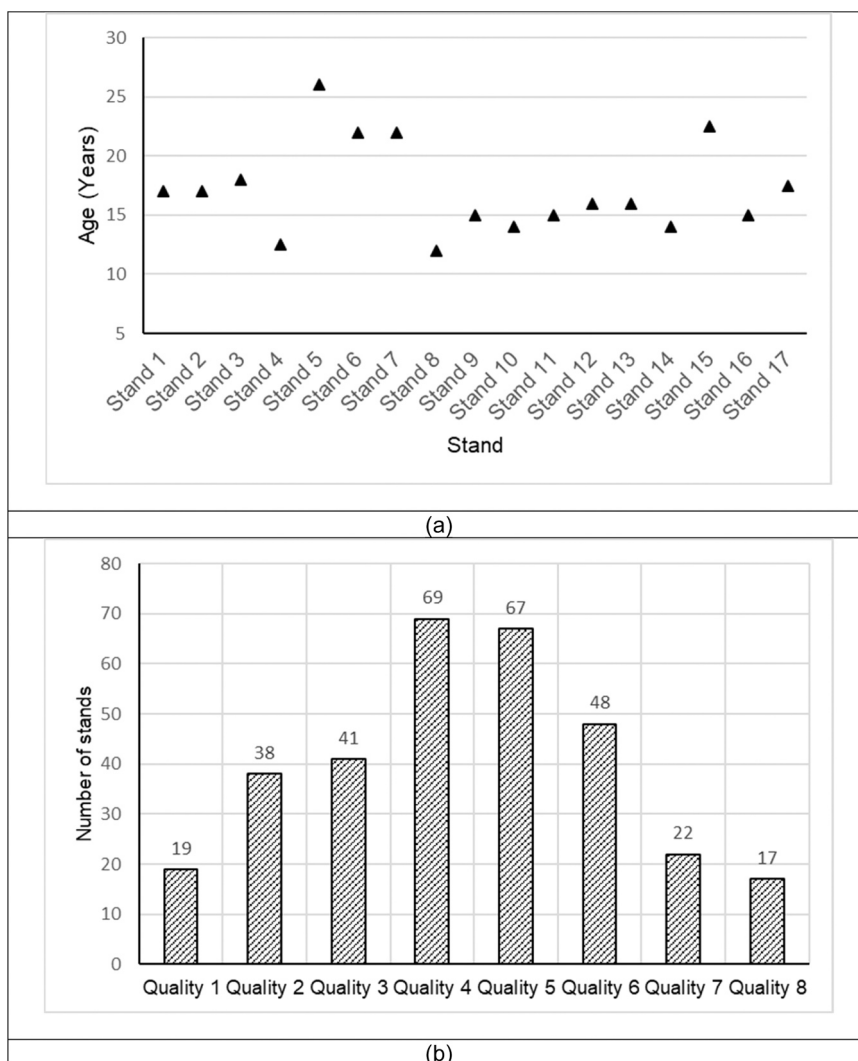

Fig. 1. Sampled plot ages and stand quality distribution in the database.

diameter, produced using a Timberjack compactor.

The average dry weight per bale was calculated considering two levels of moisture content, as reported by IDAE (2020). This allowed to estimate the total dry residual biomass per plot, enabling the definition of a relationship between the amount of harvested wood and harvested residual biomass.

Using this empirical relationship obtained from 17 plots (Fig. 1a) with varying quality levels, the results were extrapolated to a database of 321 stands (Appendix A) for which age and debarked wood volume were available. This made it possible to convert debarked wood volume into estimated bale counts, considering stand productivity.

This enabled the estimation of the number of bales as a function of plantation quality, defined as the annual debarked wood volume per hectare ($m^3 ha^{-1} yr^{-1}$). The classification of stands by quality was based on the volume of debarked wood produced per hectare per year ($m^3 ha^{-1} yr^{-1}$), following the criteria outlined in Table 1. The resulting distribution is shown in Fig. 1b.

The majority of stands belong to quality classes 4, 5, and 6, accounting for 54 % of the total. Collection efficiency was defined as the

ratio of harvested biomass to estimated biomass per hectare.

2.3. Pyrolysis experimental design

An initial full factorial design was implemented to evaluate the effects of two independent variables (temperature and nitrogen flow rate) on biochar yield from different biomass components (leaves, bark, and branches). The full factorial design included four runs, allowing the evaluation of main effects and their interactions. Five additional replicates at the central point were performed to assess the presence of curvature.

Analysis of variance (ANOVA) revealed a significant curvature effect, indicating that a linear model was insufficient. This implied that a Response Surface Methodology (RSM) should be implemented. Consequently, a Central Composite Rotatable Design (CCRD) was adopted to develop a quadratic model capable of capturing non-linear effects, comprising a 2^2 full factorial design (four experiments at the factorial points), supplemented with five center point replicates and four experiments at the axial points, totaling 13 experiments. The distance

Table 1
Criterion employed to classify the stands in the database by quality.

Quality	1	2	3	4	5	6	7	8
Productivity ($m^3 ha^{-1} yr^{-1}$)	>27	27–24	24–21	21–19	19–16	16–13	13–10	<10

between the center point and the axial points (α), was selected to ensure rotatability, where α is defined as the number of factorial experiments raised to the power of $1/4$ ($\alpha^{1/4} = \pm 1.4142$). The two variables were encoded for analysis. Temperature ranged from 300 °C to 600 °C and nitrogen flow from 0.1 to 0.3 L·min⁻¹, which are the operation limits of the equipment. These values were standardized, assigning $+\alpha$ to the highest level and $-\alpha$ to the lowest level (Table 2).

The response variable (biochar yield) was modeled using a second-order polynomial equation (Eq. (1)):

$$\hat{Y} = \beta_0 + \sum_1^n \beta_i \cdot x_i + \sum_1^n \beta_{ii} \cdot x_i^2 + \sum_{j=2}^n \sum_{i=1}^{j-1} \beta_{ij} \cdot x_i \cdot x_j \quad (1)$$

Where \hat{Y} is the predicted biochar yield (response variable), x_i and x_j are the independent variables (factors), n is the number of variables, β_0 is the intercept, β_i , β_{ii} , and β_{ij} are the constant coefficients of the linear, quadratic and interaction terms of the regression, respectively. Contour plots were generated to visualize the influence of the factors. Optimal values for biochar yield were determined using the desirability function. The individual desirability function ranges from $d(Y_j) = 0$ for a completely undesirable response to $d(Y_j) = 1$ for a fully desired response. The function $d(Y_j)$ is defined to maximize the response which is biochar yield (Eq. (2)).

$$d(Y_j) = \begin{cases} 0 & \text{if } Y_j < Y_{jmin} \\ \left[\frac{Y_j - Y_{jmin}}{Y_{jmax} - Y_{jmin}} \right]^s & \text{if } Y_{jmin} \leq Y_j \leq Y_{jmax}; s > 0 \\ 1 & \text{if } Y_j > Y_{jmax} \end{cases} \quad (2)$$

All statistical analyses were performed using Minitab 2020, with a confidence level of 95 % ($\alpha = 0.05$).

2.4. Pyrolysis procedure

Biomass residues (leaves, bark, and branches) samples from *Eucalyptus globulus* were collected. In the laboratory, samples were dried to a moisture content below 10 %, then crushed and sieved to obtain particles smaller than 5 mm.

Each experiment used 10 g of biomass, placed in a vertically oriented quartz fixed-bed reactor (360 mm length, 26 mm inner diameter) within an electric oven (ISUNI brand). High-temperature-resistant glass wool was used as a support for the biomass sample. The reactor was connected using spherical ground joints sealed with high-vacuum silicone grease.

A downward nitrogen (N₂) flow was maintained throughout the process to create an inert atmosphere, regulated using a flow controller (Brooks brand). Volatile compounds were condensed in three flasks connected in series, submerged in refrigerated baths at 0 °C. The reactor temperature was controlled using a PID controller (HC2500, CON-ATEC), with a constant heating rate of 15 °C min⁻¹. The reaction time was set to 60 minutes. A detailed schematic of the experimental setup is provided in Fig. 2.

Each pyrolysis run was conducted in triplicate. The biochar yield for each component was calculated using:

$$\text{Biochar yield}_i = \frac{\text{Mass of biochar}}{\text{Mass of raw biomass}} \cdot 100 \quad (3)$$

An ANOVA was applied to test for statistical differences among the three components. When differences were significant ($\alpha < 0.05$), a post

Table 2
Range and levels of factors in the CCRD.

Factors	Range and levels				
	$-\alpha$	-1	0	1	$+\alpha$
T ^a	300	344	450	556	600
N ₂	0.1	0.13	0.2	0.27	0.3

hoc Tukey test was used to identify which means differed.

Additionally, the total biochar yield for the residue was estimated by weighting each component's yield based on its proportion in the total biomass (Álvarez et al., 2005) and assuming a 20 % loss of leaves during handling (Pérez et al., 2024).

$$\text{Biochar}_{\text{Total residue}} = W_{\text{leaves}} \cdot \text{Biochar}_{\text{leaves}} + W_{\text{Bark}} \cdot \text{Biochar}_{\text{Bark}} + W_{\text{Branches}} \cdot \text{Biochar}_{\text{Branches}} \quad (4)$$

where $W_{\text{leaves}} = 5.27$, $W_{\text{Bark}} = 44.48$ and $W_{\text{Branches}} = 50.25$.

Finally, per-hectare revenues from residue valorization using pyrolysis for biochar production versus combustion for electricity generation were compared.

3. Results and discussion

3.1. Harvested residual biomass

Fig. 3 shows the relationship between the number of bales (Fig. 3a) and the amount of harvested residues (Fig. 3b) versus debarked stem wood in 17 *Eucalyptus globulus* stands. The linear model provided the best fit in terms of the correlation coefficient (R²).

The results gathered in Fig. 3a indicate a linear relationship between the amount of harvested biomass and the volume of debarked wood, being the number of bales slightly superior to half the cubic meters of debarked wood. This enabled a more accurate quantification of the harvested residual biomass based on the volume of debarked wood provided by the forestry processor. By applying this method to the database of debarked wood volume in 321 different stands for the last 40 years, and considering the stand classification (Table 1), the number of bales harvested per hectare was determined as a function of stand quality and age, as illustrated in Fig. 4

The relationship between the amount of harvested residual biomass and the estimated biomass according to Pérez et al. (2020b) allowed the estimation of harvesting process efficiency, which was determined in this study to be 0.69 ± 0.09 . This value is highly variable as it depends not only on the characteristics of the stands, but also on the skill of the forestry processor operators in piling the residues and the efficiency of the forestry baler. In this study, the residues were piled at the roadside by the forestry processor, leading to higher collection efficiency compared to a scenario where the residues were dispersed across the stand.

Considering the relationships presented in Fig. 4, the typical harvesting cycles (around 15 years old) in *Eucalyptus globulus* plantations and the most common quality classes (4, 5, and 6) (Fig. 1), the amount of harvested residues estimated was 188, 165, and 144 t ha⁻¹, respectively, as it is displayed in Fig. 5. A positive correlation between stand quality and the amount of harvested residual biomass is observed, being biomass yield 2.8 times higher in quality 1 stands than in quality 8 stands.

It is well known that the ratio between residual biomass and debarked wood volume increases as stand quality decreases (Pérez et al., 2020b). However, it was the higher-quality stands that produced the largest amount of dry residual biomass as a result of having more total biomass.

3.2. Pyrolysis results

3.2.1. Biochar yields

Fig. 6 presents the results of the initial factorial design (experiments 1, 2, 4, 5, 6, 9, 11, 12, and 13 from Table 3), demonstrating that curvature was significant in the biochar yield of the three residue components and the total residue ($\alpha < 0.05$). The misalignment of the central point with the extreme values (Fig. 6a) indicates the curvature effect on the biochar yield from total residue. Fig. 6b gathers the ANOVA table, confirming that this curvature is significant (p-value < 0.05). Similar

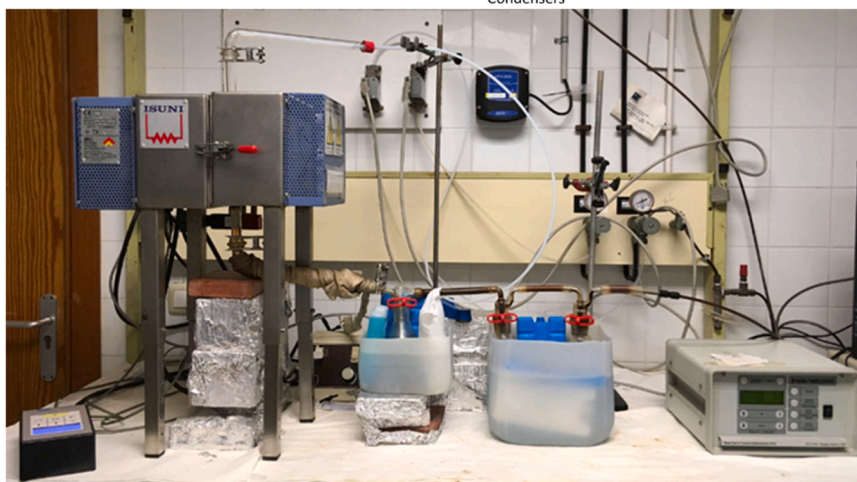
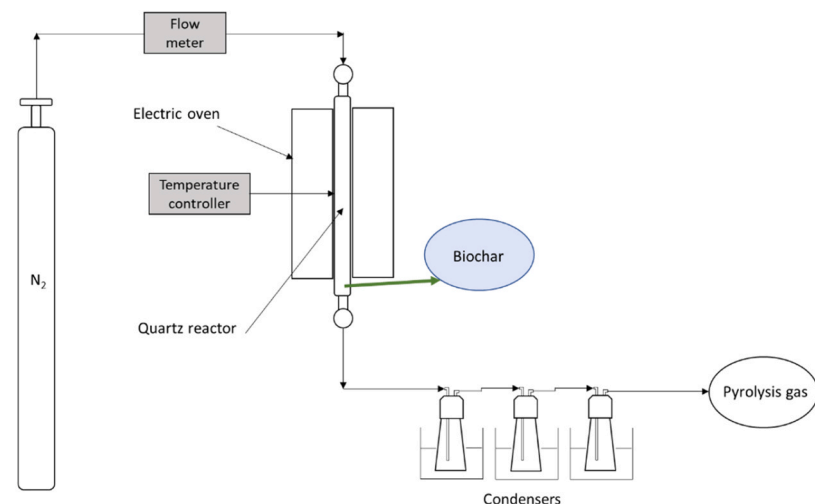
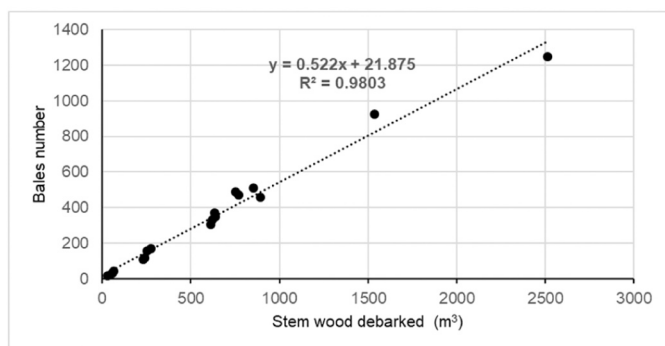
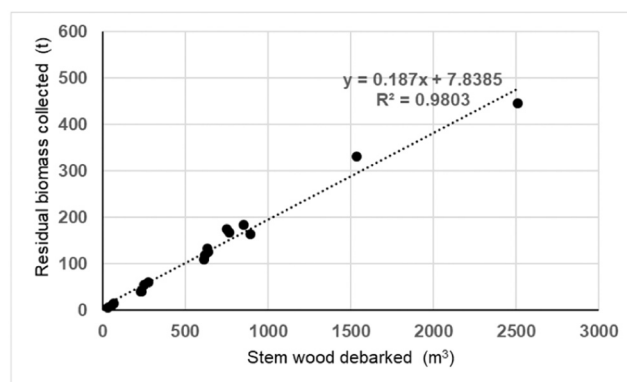

Fig. 2. Schematic diagram and photo of the experimental apparatus.



a) Bales versus wood volume



b) Amount of harvested residues versus wood volume

Fig. 3. Relationship between the harvested residual biomass and debarked stem wood in 17 stands of *Eucalyptus globulus*.

results were obtained for the three different residue components (leaves, bark and branches).

As a result of the statistical significance of the curvature, a CCRD was developed, as presented in Table 3. This table includes the experimental conditions and the biochar yield (response) results for each residue component and total residue.

In general, biochar yield increased as the pyrolysis temperature decreased which implies a reduction in the yields of liquid and gases products. Biochar yields from the total residue ranged from 49.10 % at

300 °C to 29.73 % at 600 °C. Significant differences ($\alpha < 0.05$) in biochar yield from different residue components were observed in all experiments except for experiment 7 (600 °C). The biochar production in the different fractions from highest to lowest was: % Biochar leaves > % Biochar bark > % Biochar branches.

Similar trends have been reported by other authors, with higher biochar yields from poplar bark compared to wood. This has been attributed to the fact that organic compounds in wood tend to undergo complete pyrolysis, resulting in lower char formation, while those in

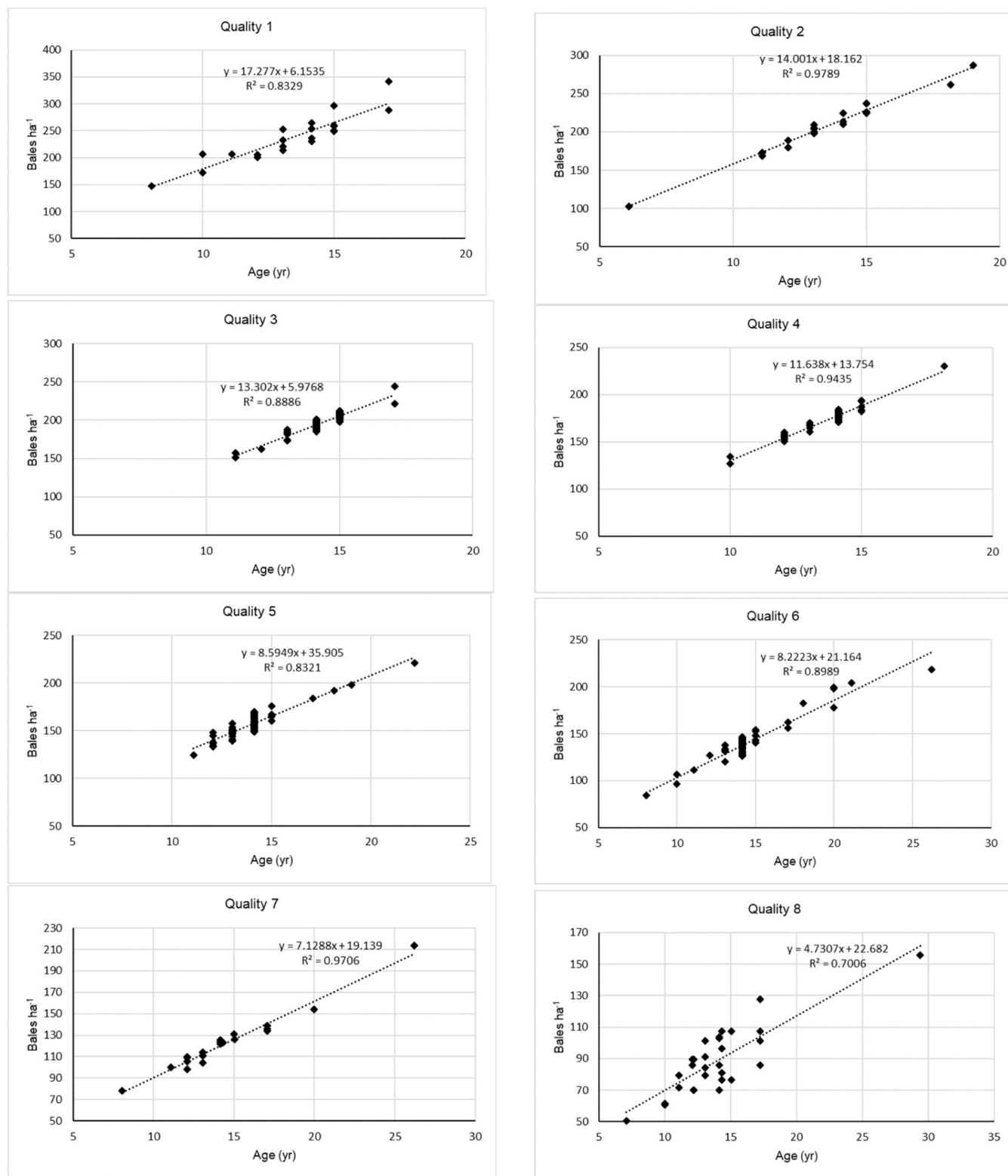

Fig. 4. Number of bales harvested as a function of stand quality and age in *Eucalyptus globulus* stands.

bark are more likely to recondense, leading to higher biochar yields (Qiu et al., 2023b). The higher biochar yield from bark compared to branches observed in this study may also be explained by the higher ash content in *Eucalyptus globulus* bark relative to its branches (Pérez et al., 2008). In contrast, there are authors who have reported biochar yield values from *Eucalyptus* leaves (species unspecified) of 72.2 % at a pyrolysis temperature of 250 °C (Liu and Balasubramanian, 2014) which exceeds the

maximum yield obtained in the present study (61.27 % at 300 °C). Additionally, other authors have reported a yield of 42.5 % from *Eucalyptus* sawdust at 350 °C (Tomczyk et al., 2020), which is comparable to the 42.91 % yield obtained from branches at 344 °C in this study.

3.2.2. Statistical analysis of pyrolysis models

Table 4 presents the analysis of variance results for biochar yield

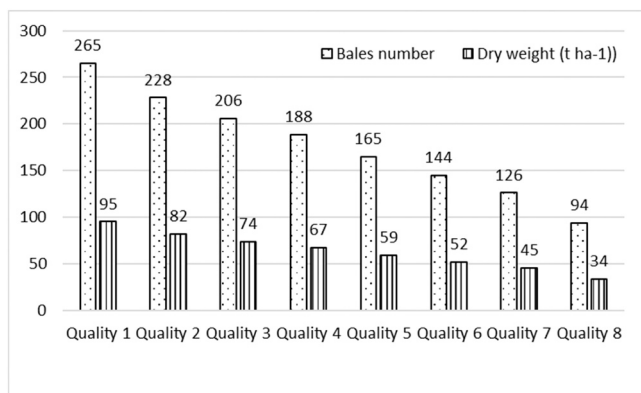

Fig. 5. Number of bales harvested and dry weight of harvested residues at 15 years.

from leaves, branches, and bark. The obtained p-value behavior confirmed the significance of the temperature, as well as temperature and N₂ flow squared for biochar yield. However, no significant effect of N₂ flow in the biochar yield was observed.

The results of the multiple regression analysis were used to obtain

Table 4

Analysis of variance (ANOVA) and regression coefficients for the responses biochar yield of total residue.

Source	Df	Biochar yield			
		SS	MS	F	p
T	1	362.93	362.93	454.54	0.000*
N ₂	1	0.766	0.766	0.96	0.360
T ²	1	37.65	37.65	47.16	0.000*
N ₂ ²	1	18.20	18.20	22.79	0.002*
T e N ₂	1	0.326	0.326	0.41	0.543
Lack of fit	3	4.512	1.504	5.58	0.065
Pure error	4	1.067	0.269		
Total SS	12	419.68			

Df: freedom degrees; SS: sum of square; MS: Mean square; p: probability of significance. * statistically significant values (p < 0.05)

the regression coefficients for the models developed of the response. The empirical equations for each response with the non-coded variables of the process (T: °C, N₂: lmin⁻¹) are given by Eq. (5).

Biochar yield from total residue(%)

$$= 114.71 - 0.2420 * T - 0.1166 * N_2 + 0.000207 * T * T + 0.000323 * N_2 * N_2 - 0.000038 * T * N_2 \quad (5)$$

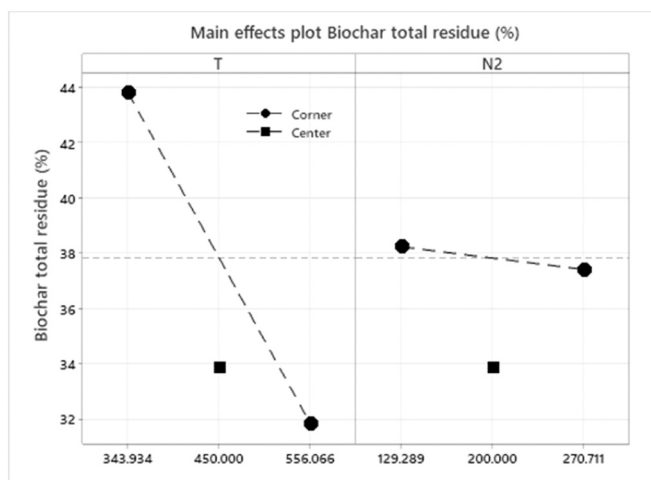

a)

Factor	Effect	F value	p value
T	-11.983	533.07	0.000
N ₂	-0.823	2.52	0.015
T*N ₂	-0.571	1.21	0.000
Curvature		128.57	0.000

b)

Fig. 6. ANOVA results for the factorial design.

Table 3

Experimental design matrix: levels of the factors and values of the responses.

Experiments		Factor levels				Response values			
Standard order	Run order	T (°C)		N ₂ (ml min ⁻¹)		Average biochar (%)			
		Coded values	Real values	Coded values	Real values	Leaves	Bark	Branches	Total residue
1	4	0	450	0	200	43.93 ^a	35.62 ^b	32.37 ^c	34.42
2	7	1	556	1	271	37.16 ^a	34.05 ^b	27.91 ^c	31.13
3	13	0	450	-1.414	100	53.96 ^a	37.13 ^b	35.89 ^c	37.39
4	6	1	556	-1	129	39.91 ^a	32.69 ^b	31.60 ^c	32.52
5	11	0	450	0	200	43.78 ^a	34.32 ^b	31.07 ^c	33.19
6	1	-1	344	1	271	47.78 ^a	44.07 ^b	42.91 ^c	43.68
7	3	1.414	600	0	200	29.93 ^a	30.15 ^a	25.78 ^b	27.94
8	12	-1.414	300	0	200	61.27 ^a	51.31 ^b	45.86 ^c	49.10
9	5	-1	344	-1	129	57.12 ^a	45.36	41.29	43.93
10	2	0	450	1.414	300	42.90	38.24 ^b	34.90 ^c	36.81
11	8	0	450	0	200	44.07 ^a	35.22 ^b	31.27 ^c	33.70
12	9	0	450	0	200	43.97 ^a	36.67 ^b	31.30 ^c	34.36
13	10	0	450	0	200	43.94 ^a	36.25 ^b	30.33 ^c	33.68

^{a,b,c} Different letters indicate significant differences of average biochar yield (dry weight) at different experiments (Tukey test $\alpha < 0.05$).

The determination coefficients ($R^2 = 98.67$ and R^2 adjusted = 97.72) demonstrate that the empirical models provide a highly accurate prediction of the experimental variability in biochar yield of the total residue.

3.2.3. Effect of operational variables (T and N_2 flow)

The influence of the factors (temperature, N_2 flow) on the biochar yield was analyzed using contour plots obtained by cutting horizontal planes of the response surface.

Fig. 7 illustrates the effects of temperature and N_2 flow on biochar yield from total residue. Lower temperatures made possible to obtain the highest biochar quantities. This decrease in biochar as temperature increases is well-documented by other authors and is due to increased primary decomposition on the biomass or secondary decomposition of the biochar residues at high temperatures, resulting in higher gas formation and a lower quantity of solid residue (Ahmed et al., 2018; Biswas et al., 2017). In this study, the lack of significance of N_2 flow on biochar yield (Table 4) is clear in Fig. 4a. Some authors (Şensöz and Angin, 2008) found that when N_2 flow exceeded 0.1 lmin^{-1} , the biochar remained constant, which aligns with the results of this study. Some authors did not observe significant changes in biochar for N_2 flows higher than 0.05 l/min , either in the slow pyrolysis of soybean cake or in the fast pyrolysis of rapeseed (Onay et al., 2001; Pütün et al., 2002).

N_2 flow is related to residence time. High N_2 flow pushes vapors out of the reactor, resulting in low residence time, which primarily has effect on the production of liquid and gaseous fractions but it does not impact significantly on char yield (Mohamed et al., 2013; Tsai et al., 2007). Other authors have published opposing results explaining that low residence time influences considerably char yield (Park et al., 2008a). According to Fassinou et al. (2009), the effect of residence time is often dominated by temperature and other parameters but can be affected firmly by the experimental setup and pyrolysis type which can explain these controversial results. The model representation (Fig. 7) indicates the non-significant influence of nitrogen flow on biochar yield when increasing the N_2 flow from 0.1 to 0.3 lmin^{-1} , as the maximum values can be observed at a temperature of $300 \text{ }^\circ\text{C}$ for both high and low flow rates.

This finding contrasts with the results of most studies, which report a decrease in biochar yield with shorter residence times—typically associated with increased N_2 flow rates (Encinar et al., 1996; Park et al., 2008b; Varma and Mondal, 2018). However, it aligns with observations from other researchers who found that while residence time influences the composition of liquid and gaseous products, it does not significantly affect char yield (Azman et al., 2022; Nasir Uddin Md. et al., 2014).

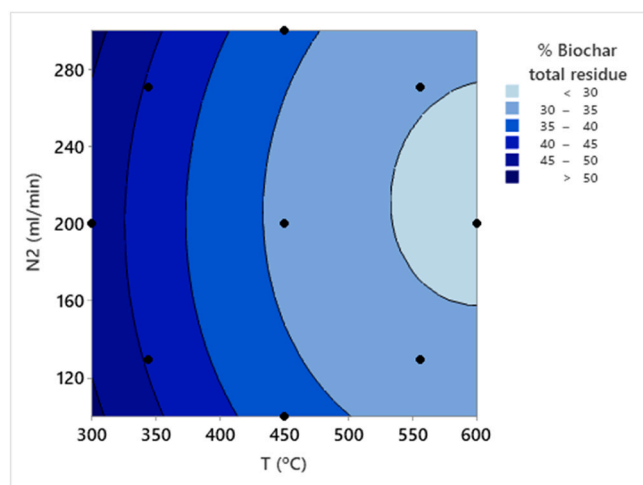

Fig. 7. Contour plots of the biochar yield responses as a function of temperature and N_2 flow.

Other authors (Azman et al., 2022), investigated flow rates between 0.4 and 1.0 lmin^{-1} and observed a peak biochar yield at 0.7 lmin^{-1} , with yields declining beyond that point. This supports the interpretation that the non-significant effect of nitrogen flow on biochar yield in this study may be due to the narrower flow range used ($0.1\text{--}0.3 \text{ lmin}^{-1}$), which remained below the threshold observed in other studies. As highlighted by other researchers (Nasir Uddin Md. et al., 2014), the relationship between vapor residence time and pyrolysis temperature in determining product yields remains a complex issue and warrants further investigation.

Pyrolysis procedure could be enhanced to optimize the products yield. The objective is to adjust the pyrolysis parameters to maximize biochar yield. In this work the objective was to maximize biochar yield while minimizing liquid and non-condensable gases (NCG) fractions yields. Fig. 8 shows the optimization results. Global desirability values between 0.8 and 1 which were achieved in this study, indicate excellent quality in the optimization, (Lazic, 2006). The conditions found by the software within the experimental domain were $300 \text{ }^\circ\text{C}$, 0.3 lmin^{-1} for maximizing biochar. From the analysis of the contour surfaces, it can be deduced that temperature is the most influential factor in optimizing product biochar.

By integrating the optimized biochar yield result (Fig. 7) with the residual biomass harvested in dry weight (Fig. 5), the potential biochar production per hectare from *Eucalyptus globulus* stands residues was estimated as a function of their quality (Fig. 9).

It can be observed that there is a reduction of more than 60% of biochar production when stands of quality 1 and 8 are compared. This decrease in biochar yield confirms the impact of the stands quality on the biochar productivity. The highest variation in biochar productivity occurs when quality 7 and 8 stands are compared, taking place a production decrease of more than 27% . The variation in biochar yields in the rest of stands is quite similar with increasing category, being this variation close to 10% of diminution as the category increases, except when quality 2 and 3 stands are compared, being the reduction in biochar yields in this case around 5% . Notably, the results in Fig. 8 were obtained under optimized conditions ($300 \text{ }^\circ\text{C}$ and 0.3 lmin^{-1}). If a higher-quality biochar is required, necessitating a higher pyrolysis temperature, this study provides sufficient data to estimate biochar yield per hectare under adjusted conditions.

3.2.4. Comparison of revenue from biochar sales vs. electricity generation from biomass residues

Considering current market prices in Spain— 83.019 €/MWh for electricity (BOE, 2024) and 130 €/t for biochar (Beston Group CO. LTD., 2024)—Fig. 10 presents an estimation of the potential revenue per hectare generated under two different valorization pathways: direct combustion and pyrolysis for biochar production. A harvest age of 15 years was assumed, along with a lower heating value of 17.1 MJ kg^{-1}

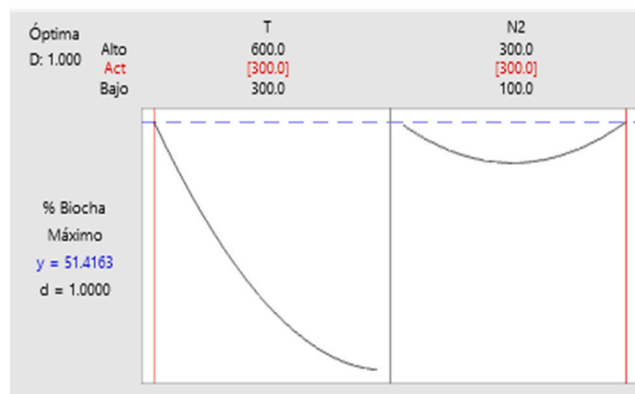

Fig. 8. Biochar yield value obtained under optimization conditions.

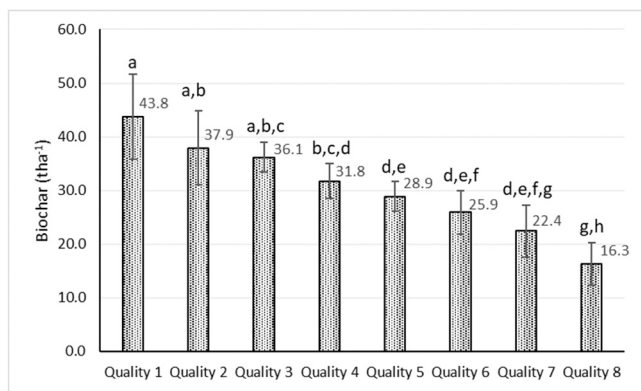

Fig. 9. Biochar yield from total residues per hectare in stands of different quality under optimization conditions. ^{a,b,c,d,e,f,g}, Different letters indicate significant differences in the average biochar yield per hectare (dry basis) among different stand qualities (Tukey's test, $\alpha < 0.05$).

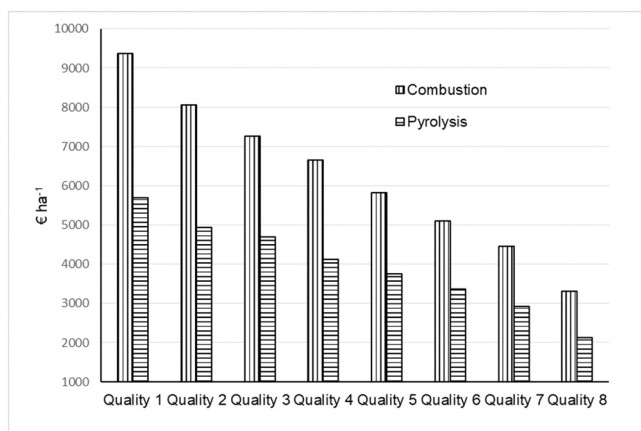

Fig. 10. Comparative analysis of revenue by stand quality, based on biochar sales and electricity generation.

and a power plant electrical efficiency of 25 % to estimate electricity generation per hectare.

As shown in Fig. 10, the revenue from biochar sales alone (excluding the value of pyrolysis liquid and gas fractions) represents approximately 60 % of the revenue obtained from electricity generation via combustion, regardless of stand quality. This estimation does not account for operational and maintenance (O&M) costs, which are often substantial in combustion-based power plants and represent a critical differentiating factor between both technologies. For the purposes of this comparison, it was assumed that the cost of transporting the biomass to the plant is similar in both cases. Ultimately, the choice of valorization pathway will depend on market dynamics, policy incentives, and the level of technological optimization achieved for each conversion process.

4. Conclusions

This study evaluated the potential biochar yield per hectare from residual biomass harvested in cylindrical bales (CRL's) from *Eucalyptus globulus* stands after timber harvesting. The amount of harvested biomass, measured based on the number of cylindrical bales (0.7 m in diameter and 3 m in length), was found to be approximately half of the debarked wood volume reported by the forestry processor. This suggests that the quantity of harvested residual biomass is influenced by stand quality, with a difference of up to 62 t ha⁻¹ observed between the highest and lowest quality at 15-year-old stands. The ratio between the

estimated residual biomass and the actual harvested biomass (harvesting efficiency) was approximately 0.69 under conditions where residues were piled at the forest roadside. Comparison of biochar yields from different residue fractions (leaves, bark and branches) revealed that leaves produced the highest ones, followed by bark and then branches. In general, biochar yield decreased with increasing pyrolysis temperature. The relationship between the response (biochar yield) and the process variables (pyrolysis temperature and N₂ flow rate) was nonlinear, as indicated by the significant curvature observed in the factorial model. Pyrolysis temperature, its quadratic term, and the quadratic term of the N₂ flow rate were found to significantly affect biochar yield. Optimization of the pyrolysis conditions indicated that the harvested residual biomass from *Eucalyptus globulus* stands could generate an average of 30.4 t ha⁻¹ of biochar. The revenue per hectare from biochar sales was estimated to represent approximately 60 % of the revenue that would be obtained from electricity generation using the same biomass. These findings contribute to identifying the most suitable biomass valorization pathways based on market conditions.

CRedit authorship contribution statement

S. Pérez: Validation, Methodology, Formal analysis, Conceptualization. **J. Fernandez-Ferreras:** Methodology, Funding acquisition. **I. Fernandez:** Methodology, Formal analysis, Conceptualization. **L. Pérez:** Writing – review & editing, Software, Resources.

Funding

This research was funded by Solvay, under projects 3399 and 3824, EUROPEAN COMMISSION, Marie Skłodowska-Curie Actions—RISE, grant number 101007733 (CELISE project) and Government of Cantabria “Bridge Projects 2023” (PID2022-138142OB-I00).

Declaration of Competing Interest

The authors declare that they have no known competing financial interests or personal relationships that could have appeared to influence the work reported in this paper.

Appendix A. Supporting information

Supplementary data associated with this article can be found in the online version at [doi:10.1016/j.indcrop.2025.121098](https://doi.org/10.1016/j.indcrop.2025.121098).

Data availability

Data will be made available on request.

References

- Ahmed, A., Abu Bakar, M.S., Azad, A.K., Sukri, R.S., Phusunti, N., 2018. Intermediate pyrolysis of *Acacia cincinnata* and *Acacia holosericea* species for bio-oil and biochar production. *Energy Convers. Manag.* 176, 393–408. <https://doi.org/10.1016/j.enconman.2018.09.041>.
- Álvarez, J.G., Balboa, M.A., Merino, A., Rodríguez, R., 2005. Estimación de la biomasa arbórea de *Eucalyptus globulus* y *Pinus pinaster* en Galicia. *Recur. Rurais* 1, 21–30.
- Aydinli, B., Caglar, A., 2012. The investigation of the effects of two different polymers and three catalysts on pyrolysis of hazelnut shell. *Fuel Process. Technol.* 93, 1–7. <https://doi.org/10.1016/j.fuproc.2011.07.009>.
- Azman, N.A.N.M.N., Asmadi, M., Nawawi, M.A.S., Amin, N.A.S., Zakaria, Z.Y., Zainol, M. M., Lubes, Z.I.Z., Phaiboonsilpa, N., 2022. Optimization of biochar production from slow pyrolysis of oil palm waste. *Chem. Eng. Trans.* 97, 163–168. <https://doi.org/10.3303/CET2297028>.
- Beston Group CO. LTD, 2024. (www.bestongroup.com/biomass-pyrolysis-plant/) [WWW Document].
- Biswas, B., Singh, R., Krishna, B.B., Kumar, J., Bhaskar, T., 2017. Pyrolysis of azolla, sargassum tenerrimum and water hyacinth for production of bio-oil. *Bioresour. Technol.* 242, 139–145. <https://doi.org/10.1016/j.biortech.2017.03.044>.
- BOE, 2024. (<https://www.boe.es/boe/dias/2024/10/01/pdfs/BOE-S-2024-237.pdf>) [WWW Document].

- Brañas, J., Gonzalez-Rio, F., Merino, A., 2000. Contenido y distribución de nutrientes en plantaciones de *Eucalyptus globulus* del noroeste de la Península Ibérica. *Sist. Y. Recur. For.* 9, 318–334.
- Bridgwater, A.V., 2003. Renewable fuels and chemicals by thermal processing of biomass. *Chem. Eng. J.* 91, 87–102. [https://doi.org/10.1016/S1385-8947\(02\)00142-0](https://doi.org/10.1016/S1385-8947(02)00142-0).
- Cheng, X., Jiang, D., Zhu, W., Xu, H., Ling, Q., Yang, J., Wang, X., Zhang, K., Zheng, X., He, S., Cao, B., Wagland, S., Wang, S., 2025. Iron and nitrogen co-doping biochar for simultaneous and efficient adsorption of oxytetracycline and norfloxacin from wastewater. *Ind. Crops Prod.* 226. <https://doi.org/10.1016/j.indcrop.2025.120646>.
- Dirección General de Montes y Conservación de la Naturaleza del Gobierno de Cantabria, 2000. IFN3. Tercer Inventario Forestal Nacional.
- Emeniye, E.C., Ogunniyi, S., Ighalo, J.O., Iwuozor, K.O., Okoro, H.K., Adeniyi, A.G., 2022. Delonix regia biochar potential in removing phenol from industrial wastewater. *Bioresour. Technol. Rep.* 19. <https://doi.org/10.1016/j.biteb.2022.101195>.
- ENCE, 2021. (<https://ence.es/wp-content/uploads/pdf/Eucalyptus.pdf>) [Accessed 15 May 2021] [WWW Document].
- Encinar, J.M., Beltran, F.J., Bernalte, A., Biro, A., Gonzalez, J.F., 1996. Pyrolysis of Two Agricultural Residues: Olive and Grape Bagasse. Influence of Particle Size and Temperature.
- Fassinou, W.F., Van de Steene, L., Toure, S., Volle, G., Girard, P., 2009. Pyrolysis of Pinus pinaster in a two-stage gasifier: influence of processing parameters and thermal cracking of tar. *Fuel Process. Technol.* <https://doi.org/10.1016/j.fuproc.2008.07.016>.
- García-Villabril, Crecente-Campo, Pérez-Cruzado, Rodríguez-Soalleiro, Diéguez-Aranda, Rojo-Alboreca, 2014. Biomass and carbon content in Galicia (NW Spain) *Eucalyptus globulus* Labill. *stands. Recur. Rurais* 10, 45–52.
- Gonzalez-Benecke, C.A., Fernández, M.P., Albaugh, T.J., Ahumada, R., Bown, H.E., Gayoso, J., Gerding, V., Mardones, O.B., Rodríguez, A.R., Rubilar, R., 2021. General above-stump volume and biomass functions for Pinus radiata, *Eucalyptus globulus* and *Eucalyptus nitens*. *Biomass Bioenergy* 155. <https://doi.org/10.1016/j.biombioe.2021.106280>.
- Grojzdek, M., Novosel, B., Klinar, D., Golob, J., Gotvajn, A.Ž., 2021. Pyrolysis of different wood species: influence of process conditions on biochar properties and gas-phase composition. *Biomass Convers. Biorefin.* 14, 6027–6037. <https://doi.org/10.1007/s13399-021-01480-3/Published>.
- Houben, D., Evrard, L., Sonnet, P., 2013. Mobility, bioavailability and pH-dependent leaching of cadmium, zinc and lead in a contaminated soil amended with biochar. *Chemosphere* 92, 1450–1457. <https://doi.org/10.1016/j.chemosphere.2013.03.055>.
- Hu, X., Guo, H., Gholizadeh, M., Sattari, B., Liu, Q., 2019. Pyrolysis of different wood species: impacts of C/H ratio in feedstock on distribution of pyrolysis products. *Biomass Bioenergy* 120, 28–39. <https://doi.org/10.1016/j.biombioe.2018.10.021>.
- IDAE, 2020. Evaluación del potencial energético de la energía de la biomasa.
- Jarvis, J.M., Page-Dumroese, D.S., Anderson, N.M., Corilo, Y., Rodgers, R.P., 2014. Characterization of fast pyrolysis products generated from several western USA woody species. *Energy Fuels* 28, 6438–6446. <https://doi.org/10.1021/ef501714j>.
- Kibblwhite, R.P., Johnson, B.I., Shelbourne, C.J.A., 2000. Kraft pulp qualities of *Eucalyptus nitens*, *E. globulus*, and *E. Maidenii* at ages 8 and 11 years. *N. Z. J. For. Sci.* 30, 447–457.
- Kulmann, M.S., de, S., Eufraide-Junior, H., de, J., Dick, G., Schumacher, M.V., de Azevedo, G.B., Azevedo, G.T., de, O.S., Guerra, S.P.S., 2022. Belowground biomass harvest influences biomass production, stock, export and nutrient use efficiency of second rotation *Eucalyptus* plantations. *Biomass Bioenergy* 161. <https://doi.org/10.1016/j.biombioe.2022.106476>.
- Kumar, A., Cameron, J.B., Flynn, P.C., 2003. Biomass power cost and optimum plant size in western Canada. *Biomass Bioenergy*.
- Lazic, Z.R., 2006. Design of Experiments in Chemical Engineering: A Practical Guide. <https://doi.org/10.1002/3527604162>.
- Liu, Z., Balasubramanian, R., 2014. Upgrading of waste biomass by hydrothermal carbonization (HTC) and low temperature pyrolysis (LTP): a comparative evaluation. *Appl. Energy* 114, 857–864. <https://doi.org/10.1016/j.apenergy.2013.06.027>.
- Londo, M., van Stralen, J., Uslu, A., Mozaffarian, H., Kraan, C., 2018. Lignocellulosic biomass for chemicals and energy: an integrated assessment of future EU market sizes, feedstock availability impacts, synergy and competition effects, and path dependencies. *Biofuels Bioprod. Bioref.* 12, 1065–1081. <https://doi.org/10.1002/bbb.1926>.
- Mani, S., Kastner, J.R., Juneja, A., 2013. Catalytic decomposition of toluene using a biomass derived catalyst. *Fuel Process. Technol.* 114, 118–125. <https://doi.org/10.1016/j.fuproc.2013.03.015>.
- Manzone, M., 2015. Efficiency of a compactor in wood chip volume reduction. *Biomass Bioenergy* 80, 303–306. <https://doi.org/10.1016/j.biombioe.2015.06.007>.
- Mateos, E., Ormaetxea, L., 2019. Sustainable renewable energy by means of using residual forest biomass. *Energies (Basel)* 12. <https://doi.org/10.3390/en12010013>.
- Mohamed, A.R., Hamzah, Z., Daud, M.Z.M., Zakaria, Z., 2013. The effects of holding time and the sweeping nitrogen gas flowrates on the pyrolysis of EFB using a fixed bed reactor. *Proc. Eng.* 185–191. <https://doi.org/10.1016/j.proeng.2013.02.024>.
- Müller-Hagedorn, M., Bockhorn, H., Krebs, L., Müller, U., 2003. A comparative kinetic study on the pyrolysis of three different wood species. *J. Anal. Appl. Pyrol.* 231–249. [https://doi.org/10.1016/S0165-2370\(03\)00065-2](https://doi.org/10.1016/S0165-2370(03)00065-2). Elsevier.
- Nasir Uddin Md, Wan Daud, W.M.A., Hazzim, F., 2014. Effects of pyrolysis parameters on hydrogen formations from biomass: a review. *RSC Adv.* 21, 10467–10490.
- Núñez-Regueira, L.N., Proupin-Castañeiras, J., Rodríguez-Añón, J.A., 2002. Energy evaluation of forest residues originated from *Eucalyptus globulus* Labill in Galicia. Oliveira, T.S., Tomé, M., 2017. Improving biomass estimation for *Eucalyptus globulus* Labill at stand level in Portugal. *Biomass Bioenergy* 96, 103–111. <https://doi.org/10.1016/j.biombioe.2016.11.010>.
- Onay, O., Beis, S.H., Kockar, O.M., 2001. Fast pyrolysis of rape seed in a well-swept fixed-bed reactor. *J. Anal. Appl. Pyrolysis* 58–59, 995–1007. [https://doi.org/10.1016/S0165-2370\(00\)00133-9](https://doi.org/10.1016/S0165-2370(00)00133-9).
- Park, H.J., Park, Y.K., Kim, J.S., 2008b. Influence of reaction conditions and the char separation system on the production of bio-oil from radiata pine sawdust by fast pyrolysis. *Fuel Process. Technol.* 89, 797–802. <https://doi.org/10.1016/j.fuproc.2008.01.003>.
- Park, H.J., Park, Y.K., Kim, J.S., 2008a. Influence of reaction conditions and the char separation system on the production of bio-oil from radiata pine sawdust by fast pyrolysis. *Fuel Process. Technol.* 89, 797–802. <https://doi.org/10.1016/j.fuproc.2008.01.003>.
- Pereira, H., Graça, J., Rodrigues, J.C., 2003. Wood chemistry in relation to quality. In: Barnett, J.R., J.G. (Eds.), *Wood Quality and its Biological Basis*. CRC Press, Blackwell Publishing, Oxford, pp. 53–83.
- Pérez, S., Fernández, L., Ortiz, F., Ortiz, A., 2024. Long-term storage and fuel quality of residual *Eucalyptus globulus* biomass. *Ind. Crops Prod.* 211. <https://doi.org/10.1016/j.indcrop.2024.118268>.
- Pérez, S., Renedo, C.J., Ortiz, A., Mañana, M., 2008. Energy potential of waste from 10 forest species in the North of Spain (Cantabria). *Bioresour. Technol.* 99, 6339–6345. <https://doi.org/10.1016/j.biortech.2007.12.014>.
- Pérez, S., Renedo, C., Ortiz, A., Ortiz, F., 2020a. Residual biomass in *Eucalyptus globulus* plantations according to stand quality. *Biomass Bioenergy* 141. <https://doi.org/10.1016/j.biombioe.2020.105699>.
- Pérez, S., Renedo, C., Ortiz, A., Ortiz, F., 2020b. Residual biomass in *Eucalyptus globulus* plantations according to stand quality. *Biomass Bioenergy* 141. <https://doi.org/10.1016/j.biombioe.2020.105699>.
- Püttin, A.E., Apaydin, E., Püttin, E., 2002. Bio-oil production from pyrolysis and steam pyrolysis of soybean-cake: product yields and composition. *Energy* 27, 703–713. [https://doi.org/10.1016/S0360-5442\(02\)00015-4](https://doi.org/10.1016/S0360-5442(02)00015-4).
- Qian, K., Kumar, A., 2015. Reforming of lignin-derived tars over char-based catalyst using Py-GC/MS. *Fuel* 162, 47–54. <https://doi.org/10.1016/j.fuel.2015.08.064>.
- Qiu, L., Li, C., Zhang, S., Wang, S., Li, B., Cui, Z., Tang, Y., Hu, X., 2023b. Distinct property of biochar from pyrolysis of poplar wood, bark, and leaves of the same origin. *Ind. Crops Prod.* 202. <https://doi.org/10.1016/j.indcrop.2023.117001>.
- Qiu, L., Li, C., Zhang, S., Wang, S., Li, B., Cui, Z., Tang, Y., Hu, X., 2023a. Distinct property of biochar from pyrolysis of poplar wood, bark, and leaves of the same origin. *Ind. Crops Prod.* 202. <https://doi.org/10.1016/j.indcrop.2023.117001>.
- Samal, B., Vanapalli, K.R., Dubey, B.K., Bhattacharya, J., Chandra, S., Medha, I., 2021. Char from the co-pyrolysis of *Eucalyptus* wood and low-density polyethylene for use as high-quality fuel: influence of process parameters. *Sci. Total Environ.* 794. <https://doi.org/10.1016/j.scitotenv.2021.148723>.
- Şensöz, S., Angin, D., 2008. Pyrolysis of safflower (*Charthamus tinctorius* L.) seed press cake: Part 1. The effects of pyrolysis parameters on the product yields. *Bioresour. Technol.* 99, 5492–5497. <https://doi.org/10.1016/j.biortech.2007.10.046>.
- Shalini, S.S., Raghavan, V., 2021. Biochar from biomass waste as a renewable carbon material for climate change mitigation in reducing greenhouse gas emissions—a review. *Biomass Convers. Biorefin.* 2247–2267. <https://doi.org/10.1007/s13399-020-00604-5/Published>.
- Sims, R.E.H., Senelwa, K., Maiava, T., Bullock, B.T., 1999. *Eucalyptus* species for biomass energy in New Zealand Part II: Coppice performance. *Biomass Bioenergy* 17, 333–343. [https://doi.org/10.1016/S0961-9534\(99\)00043-4](https://doi.org/10.1016/S0961-9534(99)00043-4).
- Tomczyk, A., Sokołowska, Z., Boguta, P., 2020. Biochar physicochemical properties: pyrolysis temperature and feedstock kind effects. *Rev. Environ. Sci. Biotechnol.* <https://doi.org/10.1007/s11157-020-09523-3>.
- Tsai, W.T., Lee, M.K., Chang, Y.M., 2007. Fast pyrolysis of rice husk: Product yields and compositions. *Bioresour. Technol.* 98, 22–28. <https://doi.org/10.1016/j.biortech.2005.12.005>.
- Varma, A.K., Mondal, P., 2018. Pyrolysis of pine needles: effects of process parameters on products yield and analysis of products. *J. Therm. Anal. Calor.* 131, 2057–2072. <https://doi.org/10.1007/s10973-017-6727-0>.
- Vasco, H., Costa, M., 2009. Quantification and use of forest biomass residues in Maputo province, Mozambique. *Biomass Bioenergy* 33, 1221–1228. <https://doi.org/10.1016/j.biombioe.2009.05.008>.
- Vecino Mantilla, S., Gauthier-Maradei, P., Álvarez Gil, P., Tarazona Cárdenas, S., 2014. Comparative study of bio-oil production from sugarcane bagasse and palm empty fruit bunch: Yield optimization and bio-oil characterization. *J. Anal. Appl. Pyrolysis* 108, 284–294. <https://doi.org/10.1016/j.jaap.2014.04.003>.
- Velázquez Martí, B., 2006. Situación de los sistemas de aprovechamiento de los residuos forestales para su utilización energética. *Ecosistemas* 15, 77–86.
- Wrobel-Tobiszewska, A., Boersma, M., Sargison, J., Adams, P., Jarick, S., 2015. An economic analysis of biochar production using residues from *Eucalypt* plantations. *Biomass Bioenergy* 81, 177–182. <https://doi.org/10.1016/j.biombioe.2015.06.015>.
- Zanli, B.L.G.L., Gblossou, K.C., Tang, W., Kamoto, M., Chen, J., 2022. A review of biochar potential in Cote d'Ivoire in light of the challenges facing Sub-Saharan Africa. *Biomass Bioenergy*. <https://doi.org/10.1016/j.biombioe.2022.106581>.
- Zhang, M., Duan, Y., Chen, T., Qi, J., Xu, T., Du, H., Si, C., 2023. Lignocellulosic materials for energy storage devices. *Ind. Crops Prod.* 203. <https://doi.org/10.1016/j.indcrop.2023.117174>.
- Zhang, L., Sun, X., 2014. Changes in physical, chemical, and microbiological properties during the two-stage co-composting of green waste with spent mushroom compost and biochar. *Bioresour. Technol.* 171, 274–284. <https://doi.org/10.1016/j.biortech.2014.08.079>.